

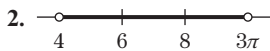
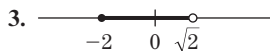
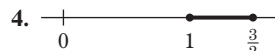
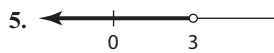

Instructor Answers

CHAPTER 0

Exercises 0.1, page 9

1.  2.  3.  4. 
5.  6.  7. $[2, 3)$ 8. $(-1, \frac{3}{2})$ 9. $[-1, 0)$ 10. $[-1, 8)$ 11. $(-\infty, 3)$
12. $[\sqrt{2}, \infty)$ 13. $f(0) = 0, f(5) = 10, f(3) = 0, f(-7) = 70$ 14. $0, 0, -\frac{9}{8}, a^3 + a^2 - a - 1$ 15. $a^2 - 1, a^2 + 2a$
16. $\frac{1}{3}, 3, \frac{a+1}{a+2}$ 17. 3 18. $h + 2$ 19. (a) 5660 (b) 10220 20. (a) Number of laptop computers sold in 2015
- (b) $f(5) = 185$ 21. $x \neq 1, 2$ 22. $t > 0 (0, \infty)$ 23. $x < 3$ 24. $x \neq 0, x \neq -2 (-\infty, -2) \cup (-2, 0) \cup (0, \infty)$

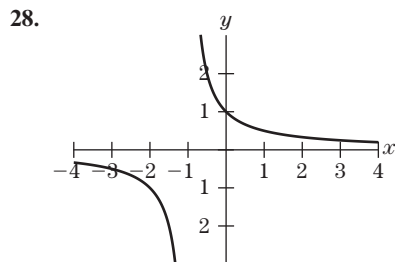
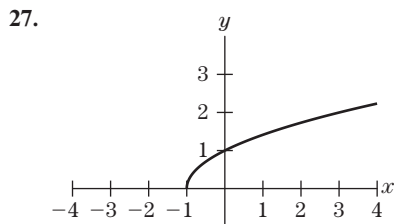
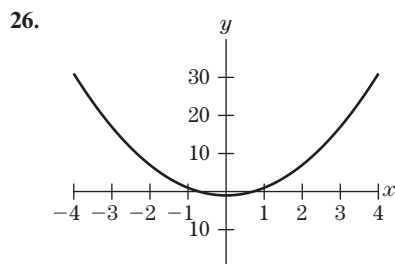
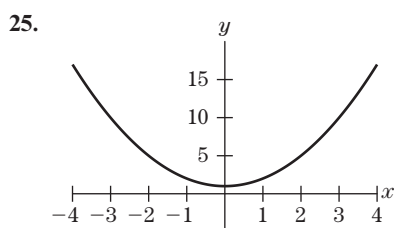

29. Function 30. Not a function 31. Not a function 32. Not a function 33. Not a function 34. Function
35. $f(0) = 1, f(7) = -1$ 36. $f(2) = 3, f(-1) = 0$ 37. Positive 38. Negative 39. $[-1, 3]$ 40. $-1, 5, 9$
41. $(-\infty, -1], [5, 9]$ 42. $[-1, 5], [9, \infty)$ 43. $f(1) \approx .03, f(5) \approx .037$ 44. $f(6) \approx .03$ 45. $[0, .05]$ 46. $t \approx 3$
47. No 48. No 49. Yes 50. No 51. $(a + 1)^3$ 52. $y = \frac{5}{2+h} - (2 + h)$ 53. 1, 3, 4
54. $f(1) = 1, f(2) = \frac{1}{2}, f(3) = 9$ 55. $\pi, 3, 12$ 56. $f(1) = 1, f(2) = 4, f(3) = 2$
57. $f(x) = \begin{cases} .06x & \text{for } 50 \leq x \leq 3000 \\ .02x + 15 & \text{for } 3000 < x \end{cases}$
 $f(3000) = .06(3000) = 180, f(4500) = .02(4500) + 15 = 105$. So \$180 and \$105

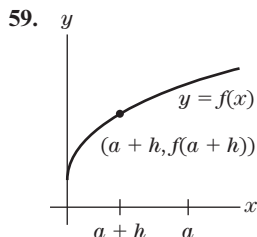
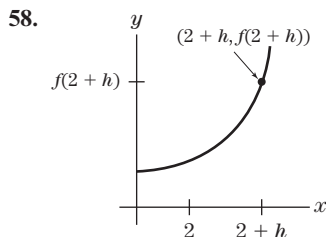

60. (a) $200/3$ (b) $350/3$ 61. You need parentheses $Y_1 = 1/(X+1)$. 62. You need parentheses $Y_1 = X^{3/4}$.

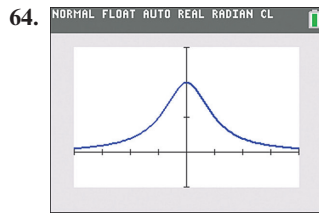
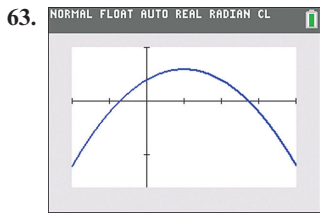

Exercises 0.2, page 18

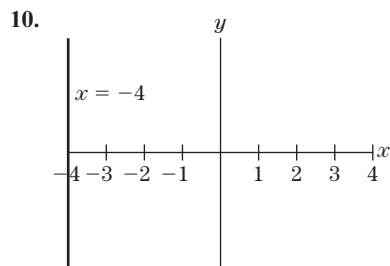
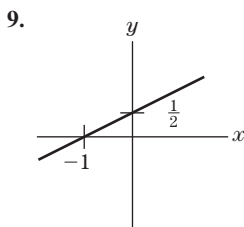
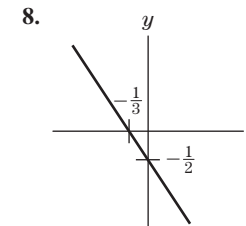
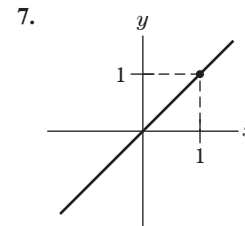
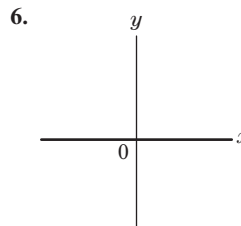
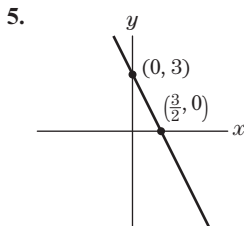
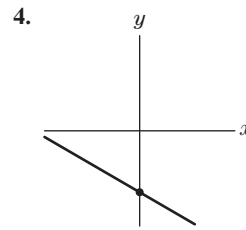
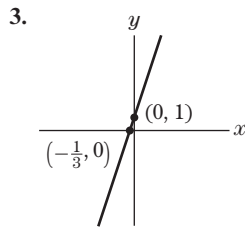
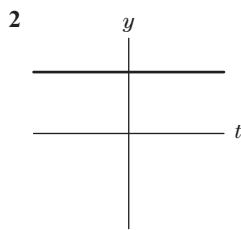
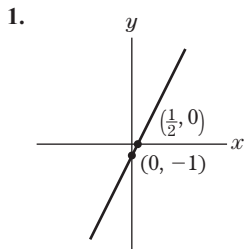

11. $(-\frac{1}{3}, 0), (0, 3)$ 12. $(0, -1), (-2, 0)$ 13. y -intercept $(0, 5)$ 14. $(0, 14)$ 15. $(0, 0)$ 16. $(0, 1), (\frac{-2}{3}, 0)$
 17. (a) \$114 (b) $f(x) = .45x + 24$ 18. $f(x) = 5000 + .10x$ 19. $700x + 1900$, x = number of days 20. 65 mph
 21. The cost for another 5% is \$25 million. The cost for the final 5% is 21 times as much. 22. (a) 100 million (b) ≈ 728.57 million
 23. (a) $K = \frac{1}{250}, V = \frac{1}{50}$ (b) $(-\frac{1}{K}, 0), (0, \frac{1}{V})$ 24. $V = \frac{1}{60}, K = \frac{1}{500}$ 25. $a = 3, b = -4, c = 0$ 26. $a = \frac{1}{3}, b = -2, c = \frac{2}{3}$
 27. $a = -2, b = 3, c = 1$ 28. $a = 4, b = -2, c = 3$ 29. $a = -1, b = 0, c = 1$ 30. $a = \frac{1}{2}, b = \sqrt{3}, c = -\pi$

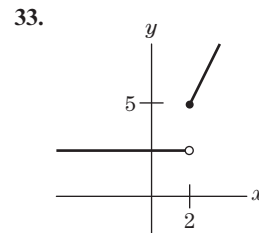
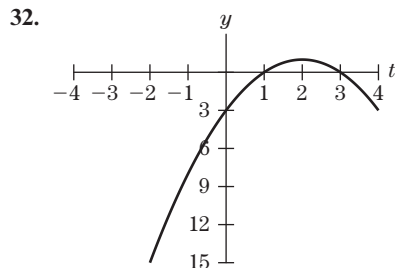
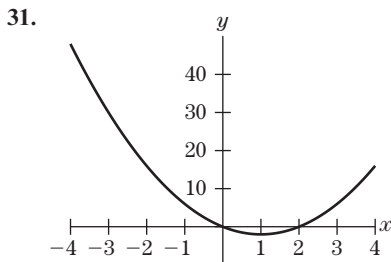

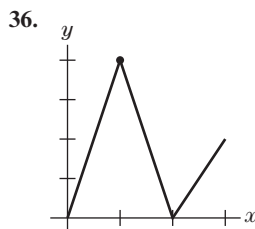
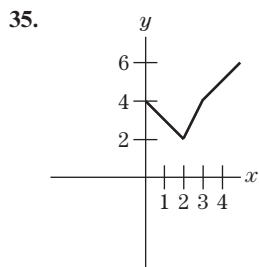
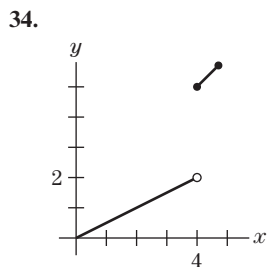

37. 1 38. $f(5) = \frac{1}{32}$ 39. 10^{-2} 40. $f(\pi) = \pi$ 41. 2.5 42. $f(-\frac{2}{3}) = \frac{2}{3}$ 43. -3985, 3008
 44. $f(-\frac{1}{2}) = -5.6875, f(3) = 133$ 45. -4.60569, 231.499 46. $f(2) = .103, f(6) = .032$

Exercises 0.3, page 23

1. $x^2 + 9x + 1$ 2. $3x^2 - 4$ 3. $9x^3 + 9x$ 4. $45x - 18x^3$ 5. $\frac{t^2 + 1}{9t}$ 6. $\frac{9t}{5 - 2t^2}$ 7. $\frac{3x + 1}{x^2 - x - 6}$ 8. $\frac{x + 6}{x^2 - 8x + 12}$
 9. $\frac{4x}{x^2 - 12x + 32}$ 10. $\frac{-2x}{x^2 + 8x + 15}$ 11. $\frac{2x^2 + 5x + 50}{x^2 - 100}$ 12. $\frac{2x^2 + 72}{x^2 - 36}$ 13. $\frac{2x^2 - 2x + 10}{x^2 + 3x - 10}$ 14. $\frac{2t^2 + 2}{3t^2 - 7t + 2}$ 15. $\frac{-x^2 + 5x}{x^2 + 3x - 10}$
 16. $\frac{-x^2 + 4x + 5}{3x^2 + 14x - 5}$ 17. $\frac{x^2 + 5x}{-x^2 + 7x - 10}$ 18. $\frac{s^2 - s - 2}{3s^2 - s}$ 19. $\frac{-x^2 + 3x + 4}{x^2 + 5x - 6}$ 20. $\frac{12x + 14}{x^2 + 7x}$ 21. $\frac{-x^2 - 3x}{x^2 + 15x + 50}$ 22. $\frac{1}{-2t + 1}$
 23. $\frac{5u - 1}{5u + 1}, u \neq 0$ 24. $\frac{1 + x^2}{3 - x^2}$ 25. $\left(\frac{x}{1 - x}\right)^6$ 26. $t^{18} - 5t^{12} + 1$ 27. $\left(\frac{x}{1 - x}\right)^3 - 5\left(\frac{x}{x - 1}\right)^2 + 1$ 28. $\frac{x^6}{1 - x^6}$ 29. $\frac{t^3 - 5t^2 + 1}{-t^3 + 5t^2}$
 30. $(x^3 - 5x^2 + 1)^6$ 31. $2xh + h^2$ 32. $\frac{-h}{x(x + h)}$ 33. $4 - 2t - h$ 34. $3t^2 + 3th + h^2$ 35. (a) $C(A(t)) = 3000 + 1600t - 40t^2$
 (b) \$6040 36. (a) $C(f(t)) = 10t^2 + 240t + 77.5$ (b) \$1197.50 37. $h(x) = x + \frac{1}{8}$; $h(x)$ converts from British sizes to U.S. sizes.

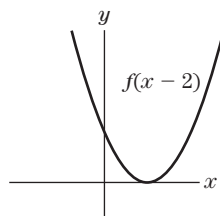
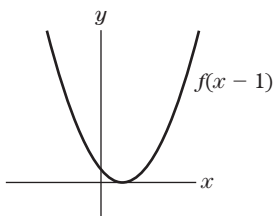
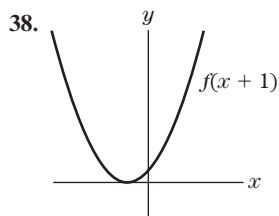

The graph of $f(x + a)$ is the graph of $f(x)$ shifted left (if $a > 0$) or right (if $a < 0$) by $|a|$ units.

39. The graph of $f(x) + c$ is the graph of $f(x)$ shifted up (if $c > 0$) or down (if $c < 0$) by $|c|$ units.

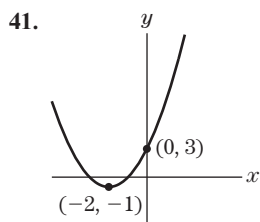
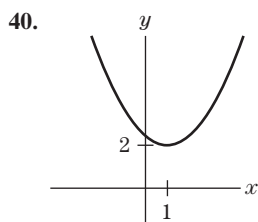

42. Not the same
 43. $f(f(x)) = x, x \neq 1$

Exercises 0.4, page 31

1. $2, \frac{3}{2}$ 2. $x = -1, \frac{1}{3}$ 3. $\frac{3}{2}$ 4. $x = -2$ 5. No zeros 6. $\frac{7 \pm \sqrt{5}}{22}$ 7. $1, -\frac{1}{5}$ 8. No solution 9. 5, 4 10. $\frac{\sqrt{2} \pm \sqrt{7}}{2}$
 11. $2 + \frac{\sqrt{6}}{3}, 2 - \frac{\sqrt{6}}{3}$ 12. $x = \frac{2}{3}$ 13. $(x + 5)(x + 3)$ 14. $(x - 2)(x - 8)$ 15. $(x - 4)(x + 4)$ 16. $(x + 1)(x - 1)$ 17. $3(x + 2)^2$
 18. $2(x - 3)^2$ 19. $-2(x - 3)(x + 5)$ 20. $-3(x - 5)(x + 1)$ 21. $x(3 - x)$ 22. $(2x + 1)(2x - 1)$ 23. $-2x(x - \sqrt{3})(x + \sqrt{3})$
 24. $-x(x - 8)(x + 2)$ 25. $(x - 1)(x^2 + x + 1)$ 26. $(x + 5)(x^2 - 5x + 25)$ 27. $(2x + 3)(4x^2 - 6x + 9)$ 28. $(x - \frac{1}{2})(x^2 + \frac{x}{2} + \frac{1}{4})$
 29. $(x - 7)^2$ 30. $(x + \frac{1}{2})^2$ 31. $(-1, 1), (5, 19)$ 32. $(9, 0), (2, -7)$ 33. $(-1, 9), (4, 4)$ 34. $(-3, 36), (-2, 21)$ 35. $(0, 0), (2, -2)$
 36. $(0, 0), (2 + 2\sqrt{2}, 4 + 4\sqrt{2}), (2 - 2\sqrt{2}, 4 - 4\sqrt{2})$ 37. $(0, 5), (2 - \sqrt{3}, 25 - 23\sqrt{3}/2), (2 + \sqrt{3}, 25 + 23\sqrt{3}/2)$
 38. $(0, 0), (2, 228)$ 39. -7, 3 40. $x = 4, 5$ 41. -2, 3 42. $x = -1, 6$ 43. -7 44. $x = 4$ 45. 16,667 and 78,571 subscribers
 46. 50 mph 47. -1, 2 48. $x = 1, -2$ 49. ≈ 4.56 50. $x = 1.17, -0.689$ 51. $\approx (-0.41, -1.83), (2.41, 3.83)$
 52. $x = \frac{1 \pm \sqrt{13}}{4} \approx -0.65$ and 1.15 53. $\approx (2.14, -25.73), (4.10, -21.80)$ 54. $x \approx 1.27, y \approx .79$ 55. $[-5, 22]$ by $[-1400, 100]$
 56. $[-5, 5]$ by $[-100, 100]$ 57. $[-20, 4]$ by $[-500, 2500]$ 58. $[-10, 20]$ by $[-100, 100]$

Exercises 0.5, page 39

1. 27 2. -8 3. 1 4. 0 5. .0001 6. 100,000,000 7. -16 8. 0.000001 9. 4 10. 3 11. .01 12. $\frac{1}{5}$ 13. $\frac{1}{6}$ 14. 2
 15. 100 16. $-\frac{1}{5}$ 17. 16 18. 8 19. 125 20. 9 21. 1 22. 27 23. 4 24. 27 25. $\frac{1}{2}$ 26. 4 27. 1000 28. 1 29. 10
 30. 27 31. 6 32. 3 33. 16 34. 9 35. 18 36. 10 37. $\frac{4}{9}$ 38. 15 39. 7 40. 1 41. x^6y^6 42. x^2 43. x^3y^3 44. x^3
 45. $\frac{1}{x^{1/2}}$ 46. xy^2 47. $\frac{x^{12}}{y^6}$ 48. $\frac{y^2}{x^2}$ 49. $x^{12}y^{20}$ 50. $1 + 2x + x^2$ 51. x^2y^6 52. x^4 53. $16x^4$ 54. $\frac{-1}{5x^3}$ 55. x^2 56. x^3y^2
 57. $\frac{1}{x^7}$ 58. $-27x^3$ 59. x 60. $\frac{1}{3\sqrt{x}}$ 61. $\frac{27x^6}{8y^3}$ 62. $\frac{1}{x^3y}$ 63. $2\sqrt{x}$ 64. $\frac{x^5}{y}$ 65. $\frac{1}{8x^6}$ 66. $4y^6$ 67. $\frac{1}{32x^2}$ 68. $\frac{125\sqrt{y}}{\sqrt{x}}$
 69. $9x^3$ 70. $\frac{-8}{y^3}$ 71. $\frac{1}{x^{5/3}}$ 72. $x^{7/3}$ 73. $\frac{1}{x^{7/3}}$ 74. $\frac{1}{x}$ 75. $\frac{1}{x^5}$ 76. $x^{7/6}$ 77. $\frac{1}{x^{5/6}}$ 78. $\frac{1}{x^{5/9}}$ 79. $\frac{1}{x^{2/3}}$ 80. $\frac{1}{x^{2/3}}$ 81. $x^{1/9}$
 82. x^4 83. $x - 1$ 84. $2x - 1$ 85. $1 + 6x^{1/2}$ 86. $\frac{1}{y} - \frac{1}{x}$ 87. $a^{1/2} \cdot b^{1/2} = (ab)^{1/2}$ (Law 5) 88. Law 6 89. 16 90. 64 91. $\frac{1}{4}$
 92. 2 93. 8 94. $\frac{1}{2}$ 95. $\frac{1}{32}$ 96. 1 97. \$709.26 98. 1295.65 99. \$127,857.61 100. \$28,515.22 101. \$164.70 102. \$522.97
 103. \$1592.75 104. \$1795.80 105. \$3268.00 106. \$26,483.83 107. $\frac{500}{256}(256 + 256r + 96r^2 + 16r^3 + r^4) = A$
 108. $\frac{125}{2}(16 + 32r + 24r^2 + 8r^3 + r^4) = A$ 109. $\frac{1}{20}(2x)^2 = \frac{1}{20}(4x^2) = 4(\frac{1}{20}x^2)$ 110. 0.00005 111. .0008103 112. 13,500,000,000,000
 113. .00000823

Exercises 0.6, page 47

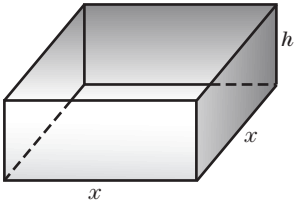
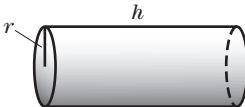
1.  2. Base = x , height = h , radius = $\frac{x}{2}$ 3.  4. Length = x , width = w , height = $\frac{x}{2}$
 5.  6. $h = \text{height}$ $\frac{h}{2} = \text{radius}$ 7. $P = 8x; 3x^2 = 25$ 8. $A = 3x^2; 30 = 8x$ 9. $A = \pi r^2; 2\pi r = 15$
 10. $P = 2r + 2h + \pi r; A = 2rh + \pi \frac{r^2}{2} = 2.5$ 11. $V = x^2h; x^2 + 4xh = 65$ 12. $S = 3xw + x^2; \frac{x^2w}{2} = 10$
 13. $\pi r^2h = 100; C = 11\pi r^2 + 14\pi rh$ 14. $30\pi = \frac{3\pi h^2}{2} V = \frac{\pi h^3}{4}$
 15. $2x + 3h = 5000; A = xh$

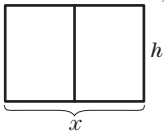

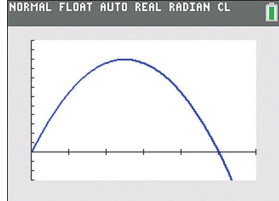
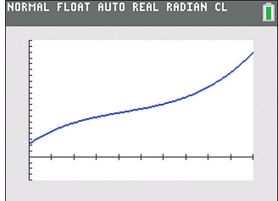
16. $2500 = lh, f = 4l + 2h$ 17. $C = 36l + 20h$ 18. $150 = 5x^2 + 16xh$ 19. 75 cm² 20. $54\pi \text{in}^2$ 21. (a) 38 (b) \$40
 22. (a) $P(100) = \$315$ (b) \$3.90 23. (a) 200 (b) 275 (c) 25 24. (a) $x = 30$ thousand subscribers (b) 500 extra subscribers
 25. (a) $P(x) = 12x - 800$ (b) \$640 (c) \$3150 26. (a) $P(12) = \$1300$ (b) $P(15) = \$3250$ 27. 270 cents 28. $r = 1, 6.87$
 29. A 100-in.³ cylinder of radius 3 in. costs \$1.62 to construct. 30. Cheapest cylinder has radius 3 and costs \$1.62 to make.
 31. \$1.08 32. 168 cents 33. $R(30) = 1800; C(30) = 1200$ 34. 20 units 35. 40 36. \$600 37. $C(1000) = 4000$
 38. Find 3500 on the y -axis. Move across to the graph and then down, finding the appropriate x . 39. Find the y -coordinate of the point on the graph whose x -coordinate is 400. 40. \$261 41. The greatest profit, \$52,500, occurs when 2500 units of goods are produced.
 42. When 1500 units are made, the profit is \$42,500. 43. Find the x -coordinate of the point on the graph whose y -coordinate is 30,000.
 44. Find 2000 on the x -axis. Move up to intercept the graph and then across to the y -axis. 45. Find $h(3)$. Find the y -coordinate of the point on the graph whose t -coordinate is 3. 46. Find the first coordinate of the highest point on the graph. 47. Find the maximum value of $h(t)$. Find the y -coordinate of the highest point of the graph. 48. Find the point where the graph intersects the t -axis. 49. Solve $h(t) = 100$. Find the t -coordinates of the points whose y -coordinate is 100. 50. Find the point where the graph intersects the y -axis.
 51. (a)  (b) 96 feet (c) 1 and 4 seconds (d) 5 seconds (e) 2.5 seconds; 100 feet
 52. (a)  (b) \$1050 (c) \$22.11 (d) 10

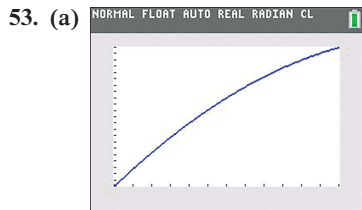

- (b) 350 bicycles per year
- (c) \$68,000
- (d) \$5000
- (e) No, revenue would only increase by \$4000.

Chapter 0: Answers to Fundamental Concept Check Exercises, page 54

1. Real numbers can be thought of as points on a number line, where each number corresponds to one point on the line, and each point determines one real number. Every real number has a possibly infinite decimal representation. A rational number is a real number with a finite or infinite repeating decimal, such as $-\frac{5}{2} = -2.5$, 1 , $\frac{13}{3} = 4.333$. An irrational number is a real number with an infinite decimal representation whose digits form no repeating pattern, such as $-\sqrt{2} = -1.414213\dots$, $\pi = 3.14159\dots$ 2. $x < y$ means x is less than y ; $x \leq y$ means x is less than or equal to y ; $x > y$ means x is greater than y ; $x \geq y$ means x is greater than or equal to y . 3. An open interval (a, b) does not contain its endpoints a and b , but a closed interval $[a, b]$ does contain a and b . 4. A function of a variable x is a rule f that assigns to each value of x a unique number $f(x)$. 5. The value of a function at x is the unique number $f(x)$. 6. The domain is the set of values that the independent variable x is allowed to assume. The range of a function is the set of values that the function assumes. 7. The graph of a function $f(x)$ is the curve that consists of the set of all points $(x, f(x))$ in the xy -plane. A curve is the graph of a function if, and only if, each vertical line cuts or touches the curve at no more than one point. 8. A linear function is of the form $f(x) = mx + b$. When $m = 0$, the function is a constant function. $f(x) = 3x - .5$ is a linear function. $f(x) = -2$ is a constant function. 9. An x -intercept is a point at which the graph of a function intersects the x -axis. The y -intercept is the point at which the graph intersects the y -axis. To find the x -intercept, set $f(x) = 0$, and solve (if possible) for x in the equation $f(x) = 0$. The y -intercept is the point $(0, f(0))$. 10. A quadratic function is of the form $f(x) = ax^2 + bx + c$, where $a \neq 0$. The graph is a parabola. 11. Quadratic function: $f(x) = ax^2 + bx + c$, where $a \neq 0$; $f(x) = -2x^2 + 4x + 9$. Polynomial function: $p(x) = a_nx^n + a_{n-1}x^{n-1} + \dots + a_0$, where n is a nonnegative integer and $a_0, a_1, \dots, a_n \neq 0$ are given numbers; $f(x) = x^5 + 3x^3 - 7x + 3$. Rational function: $h(x) = \frac{f(x)}{g(x)}$, where f and g are polynomials; $h(x) = \frac{2x - 3}{x^2 + 1}$. Power function: $f(x) = x^r$, where r is a real number; $f(x) = \sqrt{x} = x^{1/2}$. 12. $f(x) = |x|$, the absolute value of x is x , if $x \geq 0$, and $-x$ if $x < 0$. 13. Sum $f(x) + g(x)$, difference $f(x) - g(x)$, product $f(x)g(x)$, quotient $\frac{f(x)}{g(x)}$, composition $f(g(x))$. If $f(x) = 3x^2$ and $g(x) = 3x + 1$, then $f(x) + g(x) = 3x^2 + 3x + 1$, $f(x) - g(x) = 3x^2 - 3x - 1$, $f(x)g(x) = 3x^2(3x + 1) = 9x^3 + 3x^2$, $\frac{f(x)}{g(x)} = \frac{3x^2}{3x + 1}$, $f(g(x)) = 3[3x + 1]^2 = 27x^2 + 18x + 3$. 14. $x = a$ is a zero of $f(x)$ if $f(a) = 0$. 15. By factoring or using the quadratic equation. 16. $b^r b^s = b^{r+s}$, $b^{-r} = \frac{1}{b^r}$, $\frac{b^r}{b^s} = b^r \cdot b^{-s} = b^{r-s}$, $(b^r)^s = b^{rs}$, $(ab)^r = a^r b^r$, $\left(\frac{a}{b}\right)^r = \frac{a^r}{b^r}$ 17. In the formula $A = P(1 + i)^n$, A is the compound amount, P the principal amount, i the interest rate, and n the number of interest periods. 18. To solve $f(x) = b$ geometrically from the graph of $y = f(x)$, draw the horizontal line $y = b$. The line intersects the graph at a point (a, b) if, and only if, $f(a) = b$, in which case $x = a$ is a solution of $f(x) = b$. 19. To find $f(a)$ geometrically from the graph of $y = f(x)$, draw the vertical line $x = a$. This line intersects the graph at the point $(a, f(a))$.

Chapter 0: Chapter Review Exercises, page 54

- 1. $2, 27\frac{1}{3}, -2, -2\frac{1}{8}, \frac{5\sqrt{2}}{2}$ 2. $f(0) = 0, f(-\frac{1}{4}) = -\frac{5}{16}, f(\frac{1}{\sqrt{2}}) = \frac{2\sqrt{2} + 3}{2}$ 3. $a^2 - 4a + 2$ 4. $f(a + 1) = \frac{1}{a + 2} - (a + 1)^2$
- 5. $x \neq 0, -3$ 6. $x \geq 1$ 7. All x 8. $x > 0$ 9. yes 10. No 11. $5x(x - 1)(x + 4)$ 12. $3(x - 5)(x + 4)$ 13. $(-1)(x - 6)(x + 3)$
- 14. $x^3(x - 2)(x + 1)$ 15. $-\frac{2}{5}, 1$ 16. $x = \frac{-1 \pm \sqrt{17}}{4}$ 17. $\left(\frac{5 + 3\sqrt{5}}{10}, \frac{3\sqrt{5}}{5}\right), \left(\frac{5 - 3\sqrt{5}}{10}, \frac{-3\sqrt{5}}{5}\right)$
- 18. $(-\sqrt{6}, -\sqrt{6} - 5), (\sqrt{6}, \sqrt{6} - 5)$ 19. $x^2 + x - 1$ 20. $x^2 - 5x + 1$ 21. $x^{5/2} - 2x^{3/2}$ 22. $3x^3 - 7x^2 + 2x$ 23. $x^{3/2} - 2x^{1/2}$
- 24. $3x^{3/2} - x^{1/2}$ 25. $\frac{x^2 - x + 1}{x^2 - 1}$ 26. $\frac{x^3 + x^2 + x}{(x + 2)(x^2 - 1)}$ 27. $-\frac{3x^2 + 1}{3x^2 + 4x + 1}$ 28. $\frac{5x^2 + x - 2}{(x^2 - 1)(3x + 1)}$ 29. $\frac{-3x^2 + 9x - 10}{3x^2 - 5x - 8}$
- 30. $\frac{-x^2 + 3x - 1}{x^2 - 1}$ 31. $\frac{1}{x^4} - \frac{2}{x^2} + 4$ 32. $\frac{1}{(x^2 - 2x + 4)^2}$ 33. $(\sqrt{x} - 1)^2$ 34. $\frac{|x|}{1 - |x|}$ 35. $\frac{1}{(\sqrt{x} - 1)^2} - \frac{2}{\sqrt{x} - 1} + 4$
- 36. $(\sqrt{x^2 - 2x + 4} - 1)^{-1}$ 37. 27, 32, 4 38. 1000, 0.1 39. $301 + 10t + .04t^2$ 40. $R(d) = 30\left(1 - \frac{200}{d + 200}\right) - 36\left(1 - \frac{200}{d + 200}\right)^2$
- 41. $x^2 + 2x + 1$ 42. x^6/y^3 43. x 44. $8x$ 45. (a) $A(t) = 15,000\left(1 + \frac{.04}{12}\right)^{12t} = 15,000(1.0333)^{12t}$
 (b) $A(2) = \$16,247.1, A(5) = \$18,314.9$ 46. (a) $A(t) = 7000\left(1 + \frac{.09}{2}\right)^{2t} = 7000(1.045)^{2t}$ (b) $A(10) = \$16,882, A(20) = \$40,714.6$
- 47. (a) $A(r) = 15,000(1 + r)^{10}$ (b) $A(.04) \approx \$22,203.7, A(.06) \approx \$26,862.7$ 48. (a) $A(r) = 7000(1 + r)^{20}$
 (b) $A(.07) \approx \$27,087.8, A(.12) \approx \$67,524.1$